



Bagging Scale Systems

The WeighTech line of bagging scales offers processors the best in durability and operation. The scales consists of heavy duty stainless steel for the rugged environments of plant operations and is controlled by the patented MicroWeigh indicator. Firmware or product changes can be easily made by use of a hand held PDA.



Features:

- MicroWeigh controller/indicator
- Polished stainless steel construction
- Available in single, dual, or triple bagging units

Specifications:

- Single bagger: 4-5 bags per minute (10 lb bags)
- Dual bagger: 8-10 bags per minute (10 lb bags)
- Communications: RS-232, RS-485, IR, Ethernet, Bluetooth
- Control: MicroWeigh machine controller with I/O

Advantages:

- Industry proven reliability
- Ease of use - minimal training needed
- Permanently sealed MicroWeigh indicator meets the industry standards of IP69K, NEMA 4, NEMA 6, IPX7 and IPX8

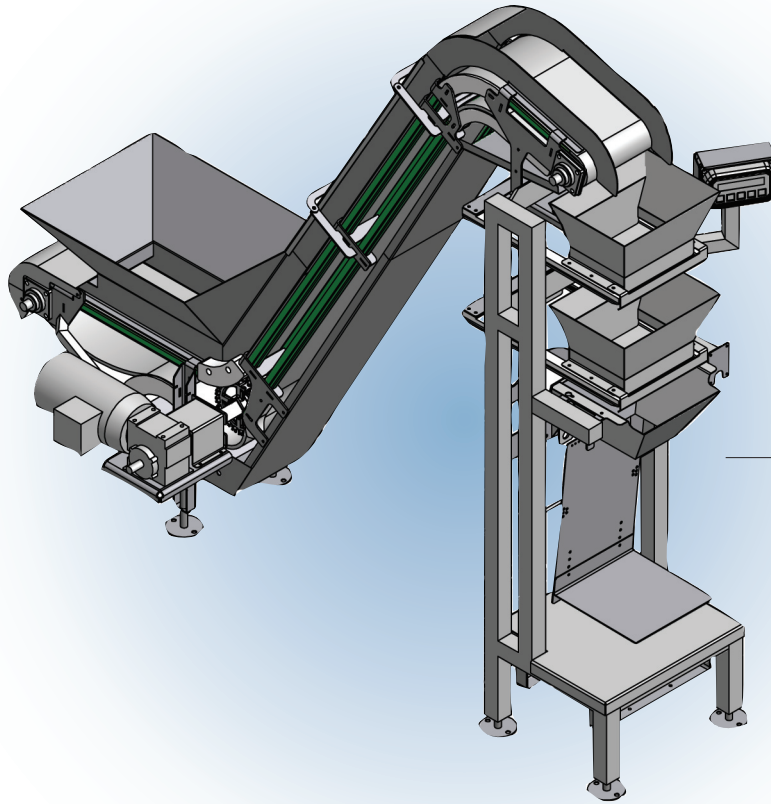

Open frame or tubular design

Polished stainless steel construction

Bagging Scale with Bulk Option

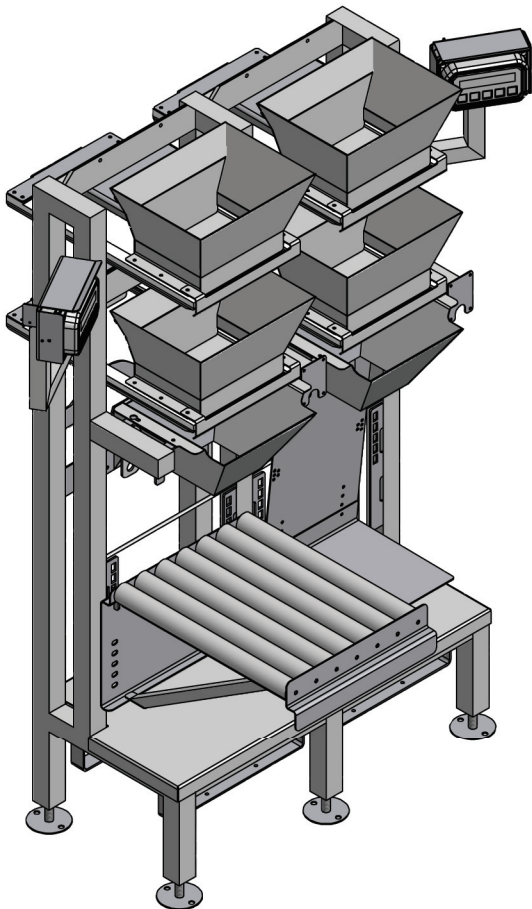

Performance:

Accuracy: + / - 0.1 lbs.

Washdown: IP69 K / NEMA 4

Physical:

Capacity: 5 to 12 lb. bag